

AceCom Networks

VCL-E1oP (2E1 Port GE Version) 2E1 over Packet / TDM over IP

Product Brochure & Data Sheet

AceCom Networks Pte Ltd.
200 Jalan Sultan, #02-13 Textile Centre,
Singapore 199018
Phone: +65 6295 3233, **Fax:** +65 6295 3133
E-mail: sales@acecomnet.com
Web Site: <http://www.acecomnet.com>

Product Overview

AceCom 'VCL-EoIP' E1 over Packet (2 E1 Port GE Version) TDM over IP equipment supports transmission of up to 2 x E1 links over IP / Ethernet, MEF or MPLS networks.

The 'VCL-E1oP' E1 over Packet (2 E1 Port GE Version) TDM over IP equipment, equipped with a powerful PowerPC 400 MHz Processor which provides a highly reliable clock recovery mechanism for low jitter and wander control, even under variable network conditions.



2 x E1 Port E1oP (E1 over Packet) TDM over IP equipment provides 2 x GigE electrical ports along with 2 x Gigabit optical ports which allow the Users to implement 1+1 add-drop (Drop-Insert), Ethernet link redundancy (Spanning Tree Protocol) and QoS by implementing Differentiated Services (Diffserv) and packet priority classification protocols for network optimization.

The 'VCL-E1oP' E1 over Packet (2 E1 Port GE Version) TDM over IP equipment also optimizes on the network usage, such that the bandwidth used by the E1oP equipment on the packet network is limited to the corresponding to the number of E1 ports and the time-slots that are being transported over the Ethernet / packet network.

Purpose of TDM Over IP technology

Telecom companies and enterprise users can save network and equipment cost and generate additional revenue by offering different types of services over a single packet-switched infrastructure by the use of E1oP equipment. The E1oP equipment is also suitable for connecting to Ethernet / packet wireless equipment to achieve fast deployment of E1 services over wireless Ethernet networks. One particular application is to build E1 links with low cost Wireless LAN bridges, replacing expensive TDM / E1 microwave radios.

The 2 x E1 over Ethernet (VCL-E1oP) multiplexer may be used to provide legacy TDM services over Gigabit Ethernet optical fiber, or wireless Ethernet/IP networks.

How the 'VCL-TDM Over IP' (2 E1 Port GE Version) equipment works

The E1 data streams received on the E1 interfaces are converted by the E1oP engine of the E1oP equipment to Ethernet data packets (of a fixed size) and transported over the Ethernet network with UDP / IP, MEF or MPLS headers. At the receiving end the E1oP reconstructs the original data streams by removing the IP, MEF or MPLS headers and converts the Ethernet data packets back to E1 frames using highly reliable and accurate clock recovery mechanism. The 'VCL-E1oP' (2 E1 port GE Version) offers the user a choice of standard, E1 to packet and packet to E1 conversion mechanisms that include SAToP and CESoPSN technologies.

Highlights

- › 19-Inch rack mountable
- › 1U form factor (44mm high)
- › 1+1 Redundant Power Supplies, AC and DC, or AC plus DC
- › Redundant power supply inputs
- › Extended Temperature Range: (-20° C to +60° C)
- › EMI / EMC Compliant
- › Real time battery backed clock with life in excess of 10 years

E1 Clock recovery and synchronization techniques:

- Adaptive Clock Recovery (ACLK)
- Recovered Clock (RCLK) / Loop-Timed Clock
- Asymmetrical (One-Clock and Two-Clock) Clock
- Synchronization to an External Clock (ECLK)
- Synchronization to an Internal Clock
- Automatic clock priority selection with fall back
- Plesiochronous Clocking

Key Features - E1 and TDM Over IP Interface

- Internal, External, Adaptive, Recovered clock and Asymmetrical (One-Clock and Two-Clock) options for the E1 TDM port synchronization. Automatic clock priority selection with fall back.
- Absolute and Differential times tamps.
- Jitter and Wander conforms to G.823 / G.824 and G.8261 and TDM specifications.
- Supports three E1 framing modes - Framed, Unframed and Multi-framed with CAS signaling.
- Supports point-to-point, point-to-multipoint and drop and insert applications.
- Supports IETF-PWE3 (pseudo-wire), SAToP and CESoPSN transport mechanisms.
- Supports CESoPSN payload mechanism to support the fractional E1 with data rate of 64Kbps to 2.048Mbps (DS0 timeslot level). User configurable data rate from 64kbps to 2048kbps, in steps of 64kbps.
- CESoPSN payload mechanism feature allows the user to optimize the packet switched network by limiting its usage to the corresponding number of timeslots carried by an E1 channel.
- Supports SAToP payload mechanism to transport full E1 (transparent to the structure of the TDM frame useful for transporting framed / unframed E1 channels).
- Supports network latency / packet delay variation / jitter buffer of up to 512ms.
- Supports IP, MPLS and MEF8 (Metro Ethernet) tagging.
- RJ45 - 120 ohms balanced E1 interfaces. Optional 75 Ohms BNC interface (120 Ohms to 75 Ohms interface converter cables provided).
- E1 Loopback facility for testing and diagnostics..

Key Features - Ethernet / IP Network Interface

- Switching Capacity upto 6 Gbps, non-blocking
- 4 GigE Ports.
- Optical SFP based (1000Base-FX) and Electrical (10/100/1000Base-T) Ethernet port options.
 - ▶ 2 x 10/100/1000BaseT Copper Ports.
 - ▶ 2 x 1000BaseFX Optical Fiber Ports.
- 4 GigE Ports Point-to-point and point-to-multipoint applications based on IP addressing.
- Supports drop and insert applications.
- Port Control Ingress Rate Limiting. 1+1 Hitless Ethernet Link Redundancy Port Trunking.
- Spanning Tree Protocol.
- IGMP Snooping.
- Supports QoS, 802.1p based packet priority.

Key Features - Ethernet / IP Network Interface Continued...

- Tagged/Un-Tagged/Un-Modified 802.1Q Mode.
- Q-in-Q Tagging.
- User configurable MTU (E1oP payload) packet size. May be configured from 1 to 1800 Bytes.
- Switch supports jumbo frame sizes of up to 9000 Bytes.
- Port based and Tag based VLANs.
- Single / Double 802.1 VLAN tagging (Q in Q VLAN Tagging) user configurable.
- Supports QoS on 802.1p based packet priority.
- Supports Packet priority assignment (IP Diffserv / DSCP).
- UDP-specific "Special" Ethernet type.
- In band VCCV ARP.
- Broadcast DA.

System Management, Monitoring and Alarm Interfaces

- NMS (Network Management System) to monitor multiple units from single Central Location.
- NMS (Network Management System) to monitor multiple units from single Central Location.
- External Alarm - Dry contact relay alarms are also available at rear of the system to connect the system to an external alarm.
- Supports system temperature monitoring with High Temperature and Low Temperature alarms and SNMP Traps.
- Supports SNMP V2 Monitoring and Traps.
- UDP-specific "Special" Ethernet type.
- Self-test for checking system errors upon system bootup.
- Event Logging.
- Clock Performance Alarms.
- Network Performance Alarms.
- Network Performance Monitoring and Diagnostics.
- Online / remote upgrade of firmware.

System Access, Control and Management Options

- Telnet.
- CLI Control Interface (HyperTerminal or VT100).
- SNMP V2 Traps (MIB File provided).
- Windows based GUI (Graphical User Interface) for easy configuration, management and access. Ability to monitor multiple units from a single NMS.
- Password Protection.

OAM: Operation and Management Ports

- RS232 Serial Port.
- USB COM Port.
- 10/100/1000BaseT Ethernet Management for In-band remote access.

Application Diagram

E1oP in Cellular Backhaul

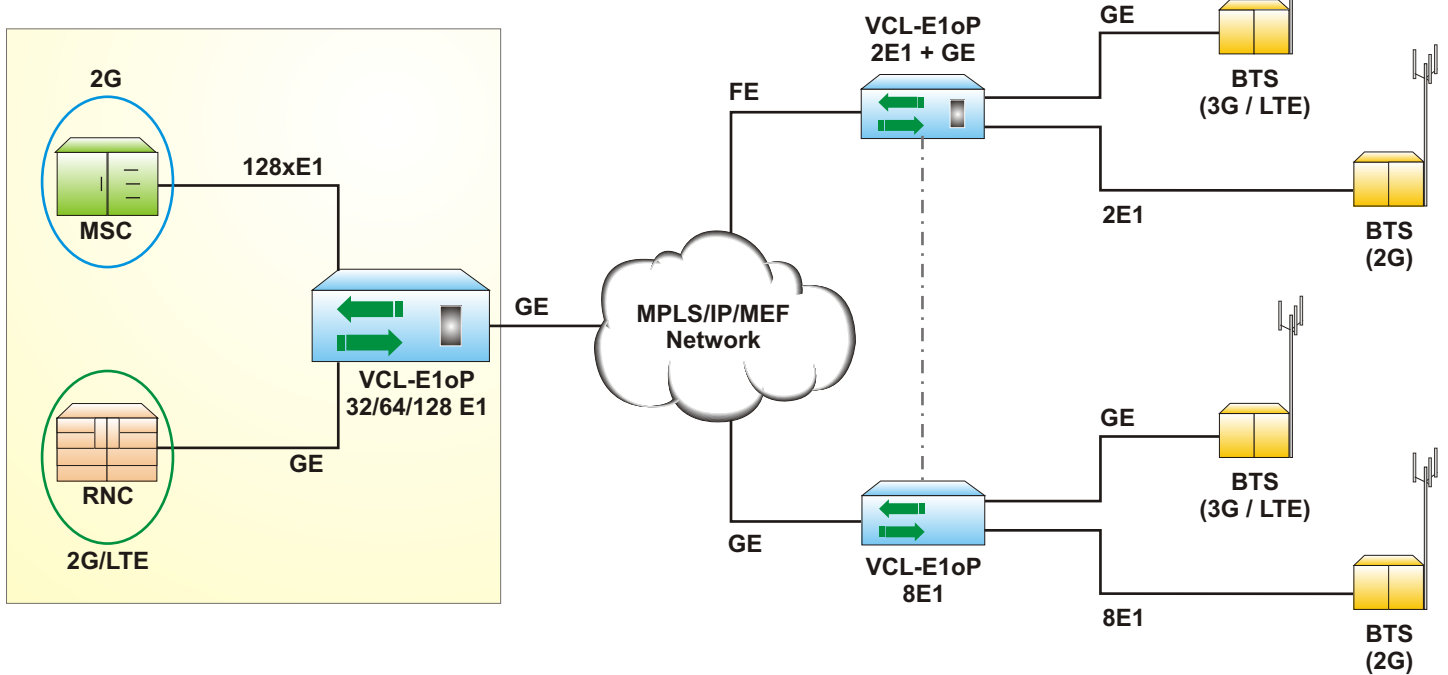

Typical Application Diagram in Wireless Network

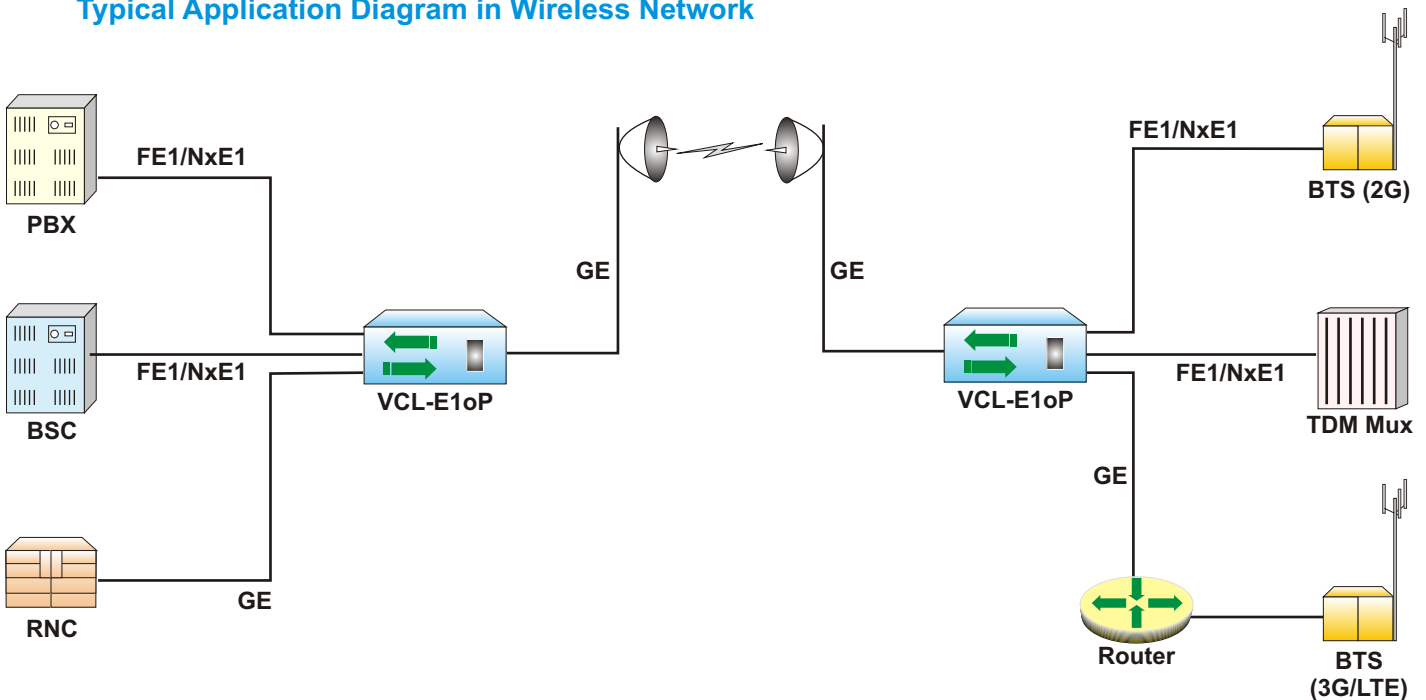

- BTS : Base Trans-receiver Station
- MSC : Master Switching Center
- RNC : Radio Network Controller
- LTE : Long Term Evolution
- FE1 : Fractional E1
- FE : Fast Ethernet
- GE : Gigabit Ethernet
- PoE : Power over Ethernet

Application Diagram

Typical Application in Wireless Network - 1+1 Link Redundancy

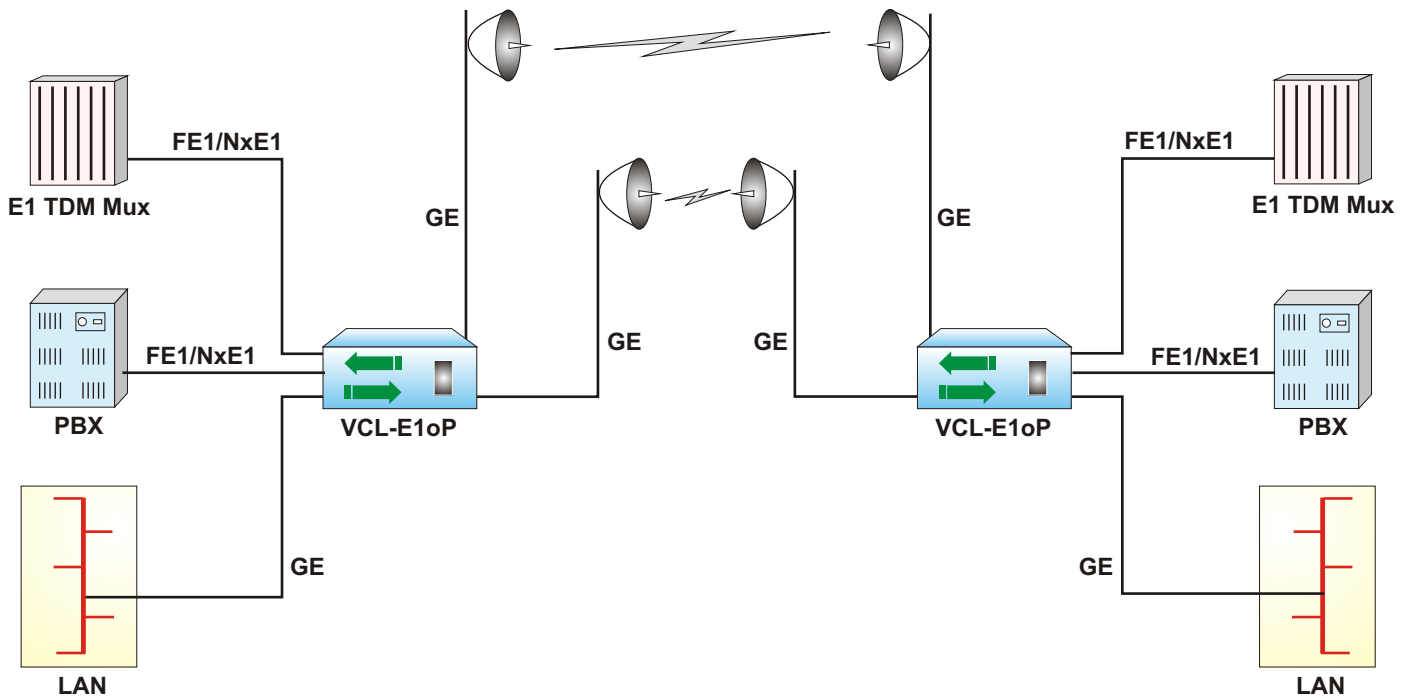

Typical Application in Wired Network

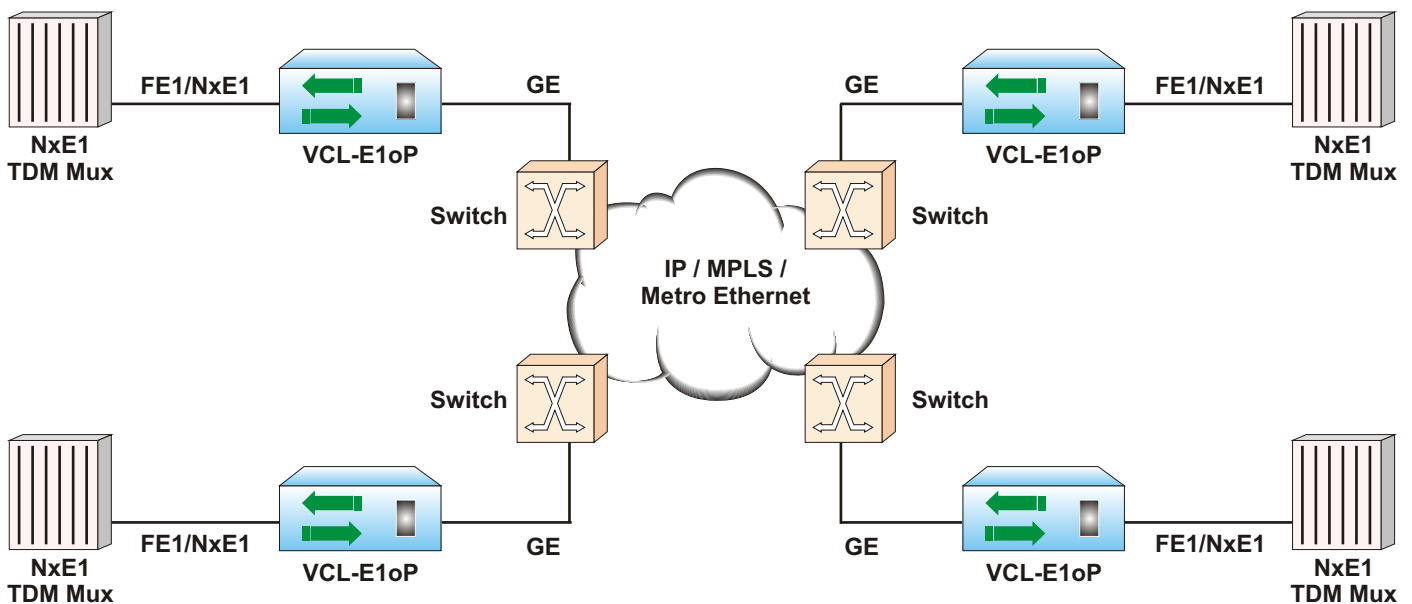

Note: Application illustrate link protection using spanning Tree Protocol between all nodes.

Application Diagram

E1s and Gigabit Ethernet Traffic over a Packet Switched Network

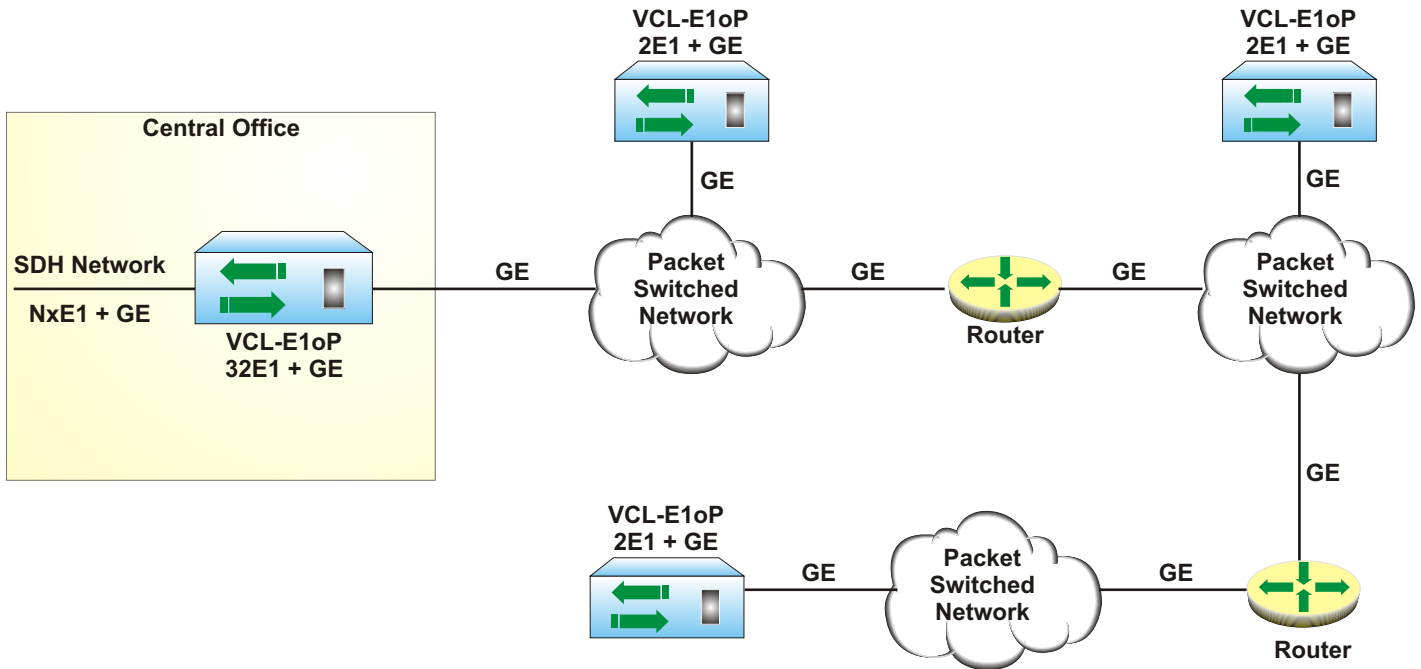

- BTS : Base Trans-receiver Station
- MSC : Master Switching Center
- RNC : Radio Network Controller
- LTE : Long Term Evolution
- FE1 : Fractional E1
- FE : Fast Ethernet
- GE : Gigabit Ethernet

Technical Specifications

E1oP Specifications

Max number of E1 Ports	Number of Ports 2
Max number of logical links	Up to 32
Synchronization clock	<ul style="list-style-type: none"> - Adaptive Clock Recovery recovery (ACLK) Options - Recovered Clock (RCLK) / Loop-Timed Clock - Asymmetrical (One-Clock and Two-Clock) Clock - Synchronization to an External Clock (ECLK) and an Internal Clock - Automatic fall back
Max number of Ethernet Ports	2 x Gigabit Optical Ethernet (SFP) 2 x 10/100/1000Base-T Electrical Ethernet
Supported Transport	ETF-PWE3, SAToP and CESoPSN Mechanisms
Supported PSN (Packet Switched Networks) type	UDP, IP, MPLS and MEF
QoS	802.1q, 802.1p packet priority

E1 Interface

Number of Ports	Number of Ports 2 (supporting 64Kbps upto 2.048Mbps on each port)
Framing Formats	Unframed, framed and Multi-frame (with or without CRC-4)
Line Coding	HDB3
Compliance	ITU-T G.703, G.704, G.706 and G.732
Jitter and Wander	Complies to ITU-T G.823,G.824
Line Impedance	120 Ohms balanced - Optional 75 Ohms
Protection	<ul style="list-style-type: none"> - Optional Metallic and Longitudinal Protection - ESD protection

Ethernet Interface

Number of Ports	2 Gigabit optical ports and 2 GigE (electrical) ports, complies with IEEE802.3, 802.1Q and 802.1P
Electrical	10/100/1000 Auto-negotiation / MDI-X (Auto-sensing), Full-Half Duplex, Rj45 Electrical Connector
Optical	1000Base-FX (Gigabit Ethernet), SFP
Protection	ESD protection
Maximum Frame Size	9000 Bytes (Jumbo Frames)
Switching Capacity	Upto 6 Gbps, Non-blocking

Gigabit Optical Ethernet Specifications

Type	SFP
Compliance	<ul style="list-style-type: none"> - Compliant with IEEE 802.3z Fast Ethernet 1000BASE-LX - MSA Compliant , RoHS, EMI, ESD, DDM
Safety	Class 1 Laser Safety/ IEC-60825 Compliant
Bit Rate	1.25 Gbps
Wavelength	1310 / 1550 nm
Distance	550m to 80Kms, as per order
Optical Connector	LC

Power Consumption

Power Consumption	<18 Watts
-------------------	-----------

Power Supply Options

- Dual Redundant (AC + DC)
- 1+1 AC power (100 to 240V AC, 50/60 Hz)
- 1+1 DC (-48V) power (40 to 72V DC)
- 1+1 DC (-24V) power (18 to 40V DC)
- AC or DC
- EMI/EMC compliant.

Command Language

- Windows based GUI (Graphical User Interface).
- 1Command Line Interface (English text commands)

Management and Control Interfaces

- COM Port (RS232 Serial Port)
- USB Port
- 10/100/1000BaseT Ethernet Port (each multiplexer may be assigned an IP address and connected to a LAN / IP network for remote access and management through the 10/100/1000BaseT Ethernet Port for in-band configuration, management and access).
- Telnet
- SNMP, V2
- Additionally, a Windows based GUI (Graphical User Interface) for easy configuration, management and access.

AC Power Supply Specifications

Input AC Voltage	110 / 220 Volts AC
Range of input AC voltage	100 V to 240 V AC, 50Hz/60Hz.
AC Input Connector	IEC Connector

24V DC Power Supply Specifications

Power Supply	24V DC
Range of input	18V to 40V DC
Input voltage reversal protection	Provided
Under voltage protection	< 4.85V
Over voltage protection	> 5.15V
Efficiency at full load	> 90% @ 5V/8A (when input voltage 24V)
Ripple at full load	< 5mVrms
Spike at full load	< 50mV

48V DC Power Supply Specifications

Power supply	-48V DC
Range of input	-40V DC to -72V DC
Under voltage protection	< 4.85V
Over voltage protection	> 5.15V
Efficiency at full load	> 91% @ 5V/10A (when input voltage -48V)
Ripple at full load	< 5mVrms
Spike at full load	< 50mV

Environment

Temperature	-20°C ~ +60°C for Operation
Humidity	5% to 95% (35°C) Non-condensing

Regulatory Compliance

- Safety - IEC 60950 Safety - IEC 60950
- CE
- RoHS
- Complies to ANS/IEC standards
- Complies with Telecom Part 68, FCC Part 15 and CISPR 22 Class A
- EMC EN55022: 1998 + A1 and A2
- EMC EN55024,
- Operation ETS 300 019 Class 3.2
- Storage ETS 300 019 Class 1.2
- Transportation ETS 300 019 Class 2.3

NMS (with Telnet) OAM port Specifications

Network Interface	RJ-45 10/100/1000BaseT (Auto sensing)
Compatibility	Ethernet Version 2.0 IEEE802.3
Protocols supported	ARP, UDP/IP, TCP/IP, Telnet, ICMP, SNMP
Management	SNMP, Serial login, Telnet login,
EMI Compliance	- Radiated and conducted emissions complies With Class B limits of EN55022:1998 - Direct and Indirect ESD complies with EN55024: 1999 - RF Electromagnetic Field Immunity complies with EN55024:1998 - Electrical Fast Transient/Burst Immunity complies with EN55024:1998 - Power Frequency Magnetic Field Immunity complies with EN55024:1998 - RF Common Mode Conducted Susceptibility complies with EN55024:1998

External Alarms

- Dry Contact Relay - 2 Form C
- Rated upto 72V DC, 1 Amp.

Chassis

- 1U High (44mm)
- 19-inch rack-mounting shelf
- Also available in Desktop / Table Top Version.

Mechanical Specification

Height	44 mm (1U)
Depth	260 mm
Width	480 mm (19 inch rack mountable)
Weight	4 Kgs.

Ordering Information

S. No.	Part #	Product Descriptions	Remarks
1	VCL-E1oP-2E1 GE-2OE-2109	VCL-2E1 over Ethernet Multiplexer (E1 over Packet / TDM over IP) 19-inch 1U High Rack Mount version Supports: <ul style="list-style-type: none"> • Upto 2 x E1 [RJ45 (F)] • 4 x Ethernet Ports (1000Mbps, Gigabit) <ul style="list-style-type: none"> › 2 x Electrical Ethernet Ports [RJ45 (F)] › 2 x Optical Ethernet Ports [1.25Gbps SFP based / without SFPs] • OAM [10/100/1000BaseT Ethernet - RJ45 (SNMP, Telnet) and Serial Port (USB and DB-9 COM Port)] Supports: <ul style="list-style-type: none"> • MPLS, MEF (Metro Ethernet) • CESoPSN, PWE3 (pseudo-wire), SAToP • E1 data rates of 64Kbps to 2.048 Mbps on each E1 port • Point-to-point, point-to-multipoint drop and insert applications • Alternate Route Protection (for 1+1 Ethernet link redundancy on WAN side) • Clocking options: Adaptive / Loop-timed / External / Internal / Asymmetrical (One-Clock and Two Clock) 	CORE UNIT without PSUs.

Power Supply Options

1	AC220	1 x 100-240V AC Power Supply Input	Any One Option.
2	DC048	1 x (-) 48V DC Power Supply Input	
3	ACDC	1 x 100-240V AC Power Supply Input 1 x (-) 48V DC Power Supply Input	
4	AC220R	2 x 100-240V AC Power Supply Input [Redundant]	
5	DC048R	2 x (-) 48V DC Power Supply Input [Redundant]	

Gigabit Ethernet SFP Options

1	VCL-EMOD 0206	1.25Gbps SFP Transceiver Duplex LC, 850nm, 550m, MMF	Maximum 2 SFPs per CORE UNIT.
2	VCL-EMOD 0205	1.25Gbps SFP Transceiver Duplex LC, 1310nm, 10Km, SMF	
3	VCL-EMOD 0231	1.25Gbps SFP Transceiver Duplex LC, 1310nm, 20Km, SMF	
4	VCL-EMOD 0255	1.25Gbps SFP Transceiver Duplex LC, 1310nm, 40Km, SMF	
5	VCL-EMOD 0155	1.25Gbps SFP Transceiver Duplex LC, 1550nm, 40Km, SMF	
6	VCL-EMOD 0256	1.25Gbps SFP Transceiver Duplex LC, 1550nm, 80Km, SMF	

Ordering Information

S. No.	Part #	Product Descriptions	Remarks
Cables and Accessories Options			As per Site Requirement.
1	VCL-HRNS 1280	1E1 75 Ohms Connectorized Cable [RJ45M-2BNC, 28cm]	
2	VCL-HRNS 1229	Optical Patch Cord Connectorized Cable [2LC-2LC, 3m, SM]	
3	VCL-HRNS 1238	Optical Patch Cord Connectorized Cable [2LC-2LC, 10m, SM]	
4	VCL-HRNS 1242	Optical Patch Cord Connectorized Cable [LC-FC, 10m, SM]	
5	VCL-HRNS 1243	Optical Patch Cord Connectorized Cable [2LC-2FC, 10m, SM]	
6	VCL-HRNS 1239	Optical Patch Cord Connectorized Cable [LC-SC, 10m, SM]	
7	VCL-HRNS 1258	Optical Patch Cord Connectorized Cable [2LC-2SC, 10m, SM]	
8	VCL-ECON 1172	Connector (Attenuator LC-LC (10 db.))	
9	VCL-ECON 1173	Connector (Attenuator LC-LC (20 db.))	
10	VCL-ECON 1186	Connector (Attenuator FC-FC (10 db.))	
11	VCL-ECON 1187	Connector (Attenuator FC-FC (20 db.))	
12	VCL-ECON 1197	Connector (Attenuator SC-SC (10 db.))	
13	VCL-ECON 1198	Connector (Attenuator SC-SC (20 db.))	
14	UMIKit2E1oPDLX	System Core Cables, Installation Accessories, Documentation, System User Manual / Disk (Set)	

- Note:**
1. SPF's to be added if 1000BaseSX/LX (Optical) Ethernet Ports are required.
 2. Redundant power supply to be added, if required.
 3. Select VCL-HRNS 1280 for E1 75 Ohms BNC (F).

Technical specifications are subject to changes without notice.
 All brand name and trademarks are the property of their respective owners.
 Revision 2.1 - February 05, 2013

AceCom Networks Pte Ltd.
 200 Jalan Sultan, #02-13 Textile Centre,
 Singapore 199018
Phone: +65 6295 3233, **Fax:** +65 6295 3133
E-mail: sales@acecomnet.com
Web Site: http://www.acecomnet.com