

# AceCom Networks

## **Ethernet over E3 Switch (Ethernet to E3 Switch)**

---

### **Product Brochure & Data Sheet**

**AceCom Networks Pte Ltd.**

200 Jalan Sultan, #02-13 Textile Centre,

Singapore 199018

**Phone:** +65 6295 3233, **Fax:** +65 6295 3133

**E-mail:** [sales@acecomnet.com](mailto:sales@acecomnet.com)

**Web Site:** <http://www.acecomnet.com>

## Product Overview

AceCom offers its Ethernet over E3 Switch (Ethernet to E3 Switch) packaged in a 19-inch rack-mountable chassis.

Ethernet over E3 Switch (Ethernet over E3 Switch) provides a 100BaseT Ethernet and 100Base-FX optical ethernet interfaces on the user side which

May be used to transport Ethernet traffic over a E3 link. Both ethernet interfaces may be used simultaneously. The Switch provides a simple and cost effective method to convert and transport ethernet data over an E3 link.

### Ethernet over E3 Switch



Front View

## Features and Highlights

- Ethernet interface to G.703 E3 34 Mbps converter
- 4x100BaseT full duplex fast ethernet interface in accordance with IEEE802.3
- 3x100BaseT full duplex fast ethernet interface + 1x100Base-FX full duplex optical ethernet interface accordance with IEEE802.3
- Framed and un-framed E3 options available
- Local and Remote access and monitoring with either RS232 or 10/100BaseT for remote management over TCP-IP network.
- Power Supply: -48V DC, Dual (1+1) protected Inputs or AC 100V to 240V AC, 50Hz / 60Hz power supply options available.
- Ethernet frame size 2016 bytes (max)
- Supports Jumbo Frames
- Accommodates up to 8192 frames with a maximum frame size of 2016 bytes
- Prevents any data overflows, or loss of packets in the event of a data burst.

## Applications

- 100 BaseT Ethernet and 100Base-FX optical to E3 conversion (Ethernet over E3).

## Indications and Alarm Monitoring

- E3 Loss of Signal
- Loss of E3 frame (in framed E3 mode)
- Loss of incoming signal at 100 BaseT ethernet
- Loss of ethernet packets, errored ethernet packets, over-sized ethernet packets and under-sized ethernet packets log.
- Configuration Error Alarm
- Clock Status
- +3 Volts Power Supply
- -48V DC present
- Configuration Error

## Programmable Features

- Telnet interface for remote programming and monitoring by using CLI text commands
- Easy to use programming using Windows based GUI.

## Status Monitoring

- Status of alarms on E3 interface
- Status of alarms on 100BaseT interface.

Ethernet Interface	
Interface Types	100BaseT and 100Base-FX optical
Standards Compliance	IEEE 802.3-2002 RFC1662 RFC2615 X.86 RMII
Interface Rate	100BaseT limited to E3 transmission rate
Protocol	HDLC/X.86 (LAPS) Encapsulation

E3 Interface	
Bit Rate	34.368 Mbps
Bit Rate Tolerance	+20ppm
Line Code	HDB3
Frame Structure	As per G.751
Interfaces	As per G.703
Connectors	BNC, Co-axial Un-balanced
Impedance	75 Ohms

### Application 1

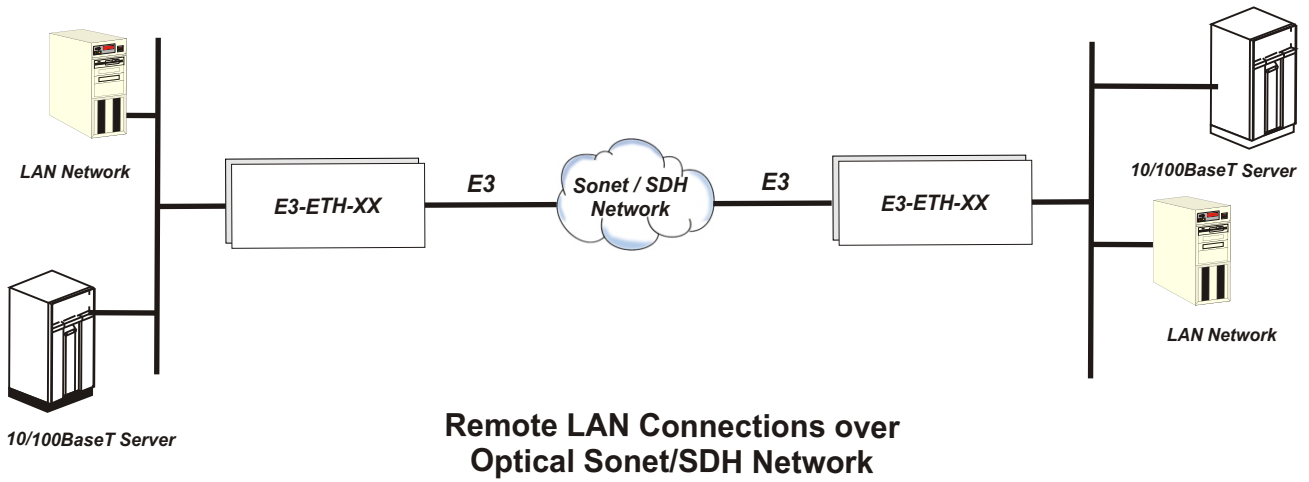

### Application 2

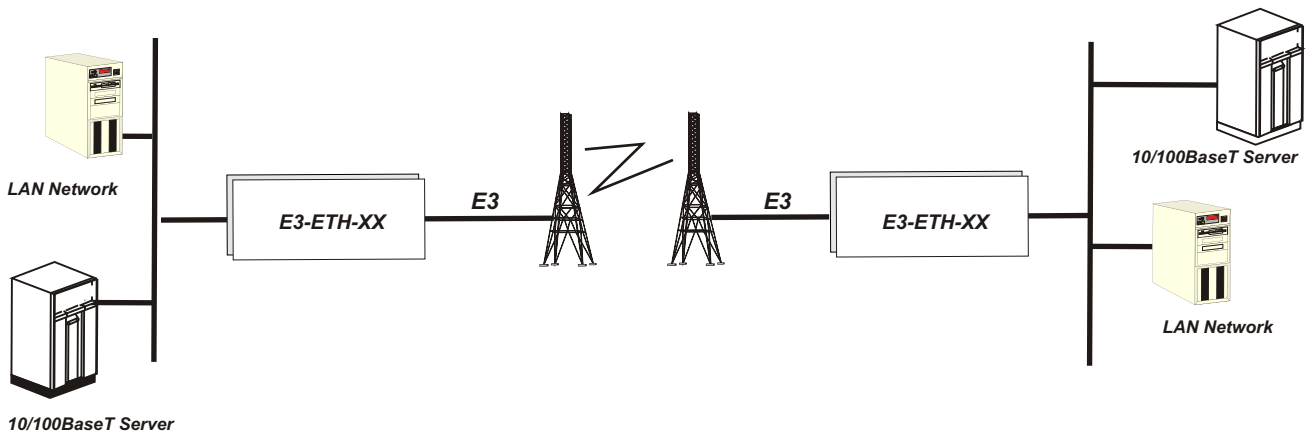

## Technical Specifications

### DC Adapter Power Supply Specifications (DC Option)

Power Supply	-48V DC (-40V DC to -60V DC)
Input DC voltage	-48V DC ( nominal )
Range of input	-40V to -60V DC
Output voltages	+3.3V
Full Load Output Current	2A at +3.3V
Input Voltage Reversal Protection	Provided in the Card
Over Current Protection	2A for +3.3V
Short Circuit Protection	Current limit - 3A. Recovers on removal of short
Under Voltage	< 3.17V
Over Voltage	3.5V
Efficiency at full load	>90%
Ripple at full load	<5mVrms
Spike at full load	<50mV

### AC Power Supply Specifications (AC Option)

Input AC voltage of AC Adapter	100 - 240 Volt AC
Range of input AC voltage	100 V to 240 V AC
System Input voltage	7.5 V DC to 9.0 V DC, DC input polarity protection.
Maximum full load output Current	2.5 A at 7.5 V DC/9.0 V DC
Input voltage reversal Protection	Provided in the Card
Efficiency at full load	>86%

### Power Supply options

Power Supply	-48V DC (-40V DC to -60V DC) (Optional)*
Power Supply	AC input (Optional)*

\* Please specify the Power Supply Option (AC or DC) which is required before placing the order. Please see ordering information in this data sheet for details.

### Power Consumption

Power Consumption	9 Watts
-------------------	---------

### Chassis

1U High (42 mm)
19-inch rack-mounting shelf.

### Number of Ethernet Interface

10/100BaseT (Electrical)	4
10/100BaseT Electrical +100Base FX Optical	3 Electrical and 1 Optical

### 100BaseT Interface (Electrical Ethernet)

Interface Types	100BaseT
Standards Compliance	IEEE 802.3-2002 RFC1662 RFC2615 X.86 RMII
Interface Rate	100BaseT limited to E3 transmission rate
Protocol	HDLC/X.86 (LAPS) Encapsulation
Connectors	RJ-45 (100 BaseT Electrical)

### 100Base-FX Interface (Optical Ethernet)

Interface Types	100Base-FX
Standards Compliance	IEEE 802.3-2002 RFC1662 RFC2615 X.86 RMII
Interface Rate	100Base-FX optical limited to E3 transmission rate
Protocol	HDLC/X.86 (LAPS) Encapsulation
Connectors	SC

### Ethernet Interface Specifications - 100Base-FX (Optical) - 850nm Multi Mode Transmitter Optical Characteristics

Parameter	Minimum	Typical	Maximum
Data Rate		125Mb/s	
Center Wavelength	830nm	850nm	860nm
Output Spectral Width (RMS)			0.85nm
Average Output power	-10dBm		-3dBm
Output optical Eye	Complaint with ITU-T G.957		
Connectors	SC		

**Receiver Optical Characteristics**

Parameter	Minimum	Typical	Maximum
Data Rate		125Mb/s	
Receive Sensitivity	-24dBm		
Maximum Input Power			-3dBm
Operating Wavelength	-10dBm	850nm	
Connectors	SC		

**Ethernet Interface Specifications - 100Base-FX (Optical) - 1310nm Single Mode**

**Transmitter Optical Characteristics**

Parameter	Minimum	Typical	Maximum
Data Rate		125Mb/s	
Center Wavelength	1260nm	1310nm	1360nm
Output Spectral Width (RMS)			6nm
Average Output power	-15dBm	-12dBm	-8dBm
Output optical Eye	Complaint with ITU-T G.957		
Connectors	SC		

**Receiver Optical Characteristics**

Parameter	Minimum	Typical	Maximum
Data Rate		125Mb/s	
Receive Sensitivity	-32dBm		
Maximum Input Power			-15dBm
Operating Wavelength	1100nm		1600nm
Connectors	SC		



**Ethernet Interface Specifications - 100Base-FX (Optical) - 1550nm Single Mode**

**Transmitter Optical Characteristics**

Parameter	Minimum	Typical	Maximum
Data Rate		125Mb/s	
Center Wavelength	1480nm	1550nm	1580nm
Output Spectral Width (RMS)			4nm
Average Output power	-15dBm	-12dBm	-8dBm
Output optical Eye	Complaint with ITU-T G.957		
Connectors	SC		

**Receiver Optical Characteristics**

Parameter	Minimum	Typical	Maximum
Data Rate		125Mb/s	
Receive Sensitivity	-32dBm		
Maximum Input Power			-15dBm
Operating Wavelength	1100nm		1600nm
Connectors	SC		

**E3 Interface**

Number of E3 Interfaces	1
Bit rate	34.368 Mbps
Bit rate tolerance	+/- 20ppm
Line code	HDB3
Frame structure	As per G.751
Interfaces	As per G.703
Connectors	BNC, Co-axial Un-balanced
Impedance	75 Ohms
Permissible attenuation	12dB @ 17184 KHz
Signal level to declare loss of signal condition	-35dB (maximum)
Signal level to clear loss of signal condition	-15dB (minimum)

**Clock**

Internal	System Internal Clock
Loop-Timed	Timed from E3 Interface

**Management and Control**

Serial Management Port - RS232 Interface
10/100 BaseT for Remote Management over a LAN
10/100 BaseT Telnet over a TCP-IP Network

**Command Language**

Command Line Interface (English text commands)
Windows based GUI (optional)

**NMS (with Telnet) XPort Specifications**

Network interface	RJ-45 Ethernet 10BaseT or 100BaseT-TX (auto sensing)
Compatibility	Ethernet Version 2.0 IEEE802.3
Protocols supported	ARP, UDP/IP, TCP/IP, Telnet, ICMP, SNMP, DHCP, BOOTP, TFTP, Auto IP, SMTP and HTTP
LEDs	10Base-T and 100Base-TX Activity, Full/half duplex
Management	Internal web server, SNMP (read only), Serial login, Telnet login
EMI compliance	Radiated and conducted emissions - complies with Class B limits of EN55022:1998 Direct and Indirect ESD - complies with EN55024:1998 RF Electromagnetic Field Immunity - complies with EN55024:1998 Electrical Fast Transient/Burst Immunity - complies with EN55024:1998 Power Frequency Magnetic Field Immunity - complies with EN55024:1998 RF Common Mode Conducted Susceptibility - complies with EN55024:1998



## Ordering Information

Ethernet over E3 Switch		
S. No.	Part #	Product Description
1.	E3-ETH-DC-DLX	4 x Ethernet over E3 Switch -48V DC Input 4 Ethernet (10/100BaseT Electrical RJ45F) E3 (75 Ohms BNCF) (unframed and framed E3 - user selectable)
2.	E3-ETH-AC-DLX	4 x Ethernet over E3 Switch 100-240V AC Power Input 4 Ethernet (10/100BaseT Electrical RJ45F) E3 (75 Ohms BNCF) (Unframed and framed E3 - user selectable)

Technical specifications are subject to change without notice.  
 Revision 10 - April 15, 2011.

**AceCom Networks Pte Ltd.**  
 200 Jalan Sultan, #02-13 Textile Centre,  
 Singapore 199018  
**Phone:** +65 6295 3233, **Fax:** +65 6295 3133  
**E-mail:** sales@acecomnet.com  
**Web Site:** <http://www.acecomnet.com>