

AceCom Networks

VCL-4 Ethernet over 1E1 E1/4*10/(100) Base-T Interface Converter

Data Sheet & User Manual

AceCom Networks Pte Ltd.

200 Jalan Sultan, #02-13 Textile Centre,

Singapore 199018

Phone: +65 6295 3233, **Fax:** +65 6295 3133

E-mail: sales@acecomnet.com

Web Site: <http://www.acecomnet.com>

Description

The VCL-4 Ethernet over E1 Converter provides the user a facility to transport Ethernet (multiple LANs) over an E1 link. The equipment converts and transports up to 4 x Ethernet links over an E1 in a shared* mode, or a discrete** mode, depending on the user's preference and selection.



VCL-4 Ethernet over 1E1

***In shared mode:** All 4 Ethernet channels are transported over the same shared E1 link and are allowed full access to each other's path. The user may select this mode if the user desires that all of the 4 x Ethernet links that are being transported over the same E1 to optimally share its bandwidth resources and where discretion is essential.

***In discrete mode:** All 4 Ethernet channels are transported over the same E1 link, but without allowing intrusion or access to each other's path. The user may select the discrete* mode when the user desires to transport all 4 Ethernet channels over the same E1 line discretely, and without allowing access to each other.

The equipment shall always be installed and used in pairs, with one terminal being installed at either end (each side) of the network.

The VCL-4 Ethernet over E1, E1/4*10(100)Base-T Interface Converter is an ethernet extension device utilizing TDM telecom infrastructure (the telecom network of E1s, or of PDH, SDH and E1/E3/SDH microwave etc. carrying E1s).

The VCL-4 Ethernet over E1, E1/4*10(100)Base-T Interface Converter converts the Ethernet Data into E1 frame format for transmission over the existing TDM (E1) links and then re-converts the E1s back into Ethernet Data at the far-end terminal. Its function is to primarily provide a BRIDGE between two Ethernet LANs over the existing E1 based telecom network. The device can effectively utilize the redundant bandwidth of telecom operators' existing TDM network to transport Ethernet data with low investment.

*Optional powers 220V AC and -48V DC. May be ordered with either power option.

Applications

This equipment may be used for the following purposes:

1. Bridging Ethernet LANs over existing TDM (E1) telecom network. Extending Ethernet Networks utilizing TDM (E1) landline based telecom infrastructure.
2. Using telecom network of E1s/PDH/SDH Microwave etc. carrying E1s to transport Ethernet Data.

In all these cases the equipment be always installed and used in pairs, with one terminal being installed at either end (each side) of the network.

Typical Application

Shared link mode

In the "**shared link mode**", each LAN can view and talk to other LANs. Example: each LAN can view and talk to all other LANs at same site or the corresponding remote side. This mode may be selected for use if bandwidth optimization and usage is of prime importance and the user is not averse to sharing the E1 link resources with the other LANs being transported on the same E1 link.

For example all four Ethernet Ports at local site are in LAN Mode and will also communicate to all four Ethernet Ports at far end site.

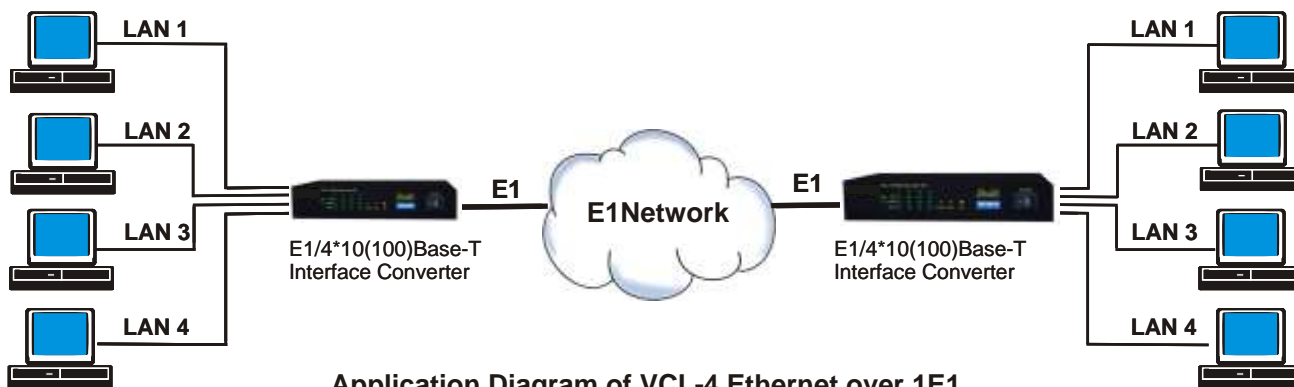

Application Diagram of VCL-4 Ethernet over 1E1 Converter in V LAN Mode "shared link mode"

Note: In the "shared link mode", the VLAN switch must be OFF (The ethernet ports are not isolated to each other on both sides of the E1 link).

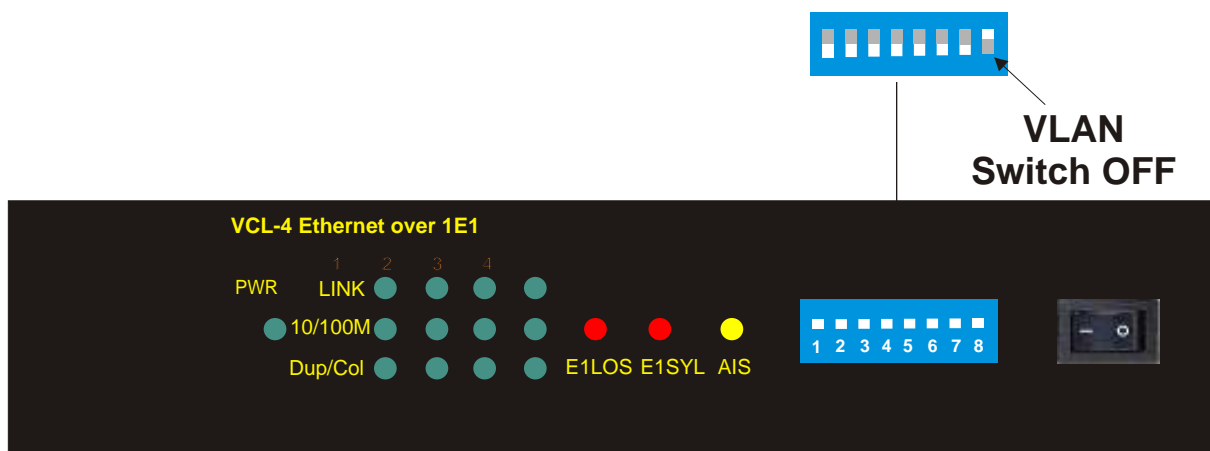

Note: Each DIP Switch is ON in downside and OFF in Upside.

Discrete link mode

In the "discrete link mode" each LAN is bridged to, and can only talk to its corresponding LAN on the remote side. It can not talk to any other LAN either at same side or the remote side. This mode may be selected for use if the users do not wish to share the E1 link resources with the other LANs being transported on the same E1 link.

For example the Ethernet Port 1 (at local site) will communicate to Ethernet Port 1 at far end site and so on for Port 2 etc.

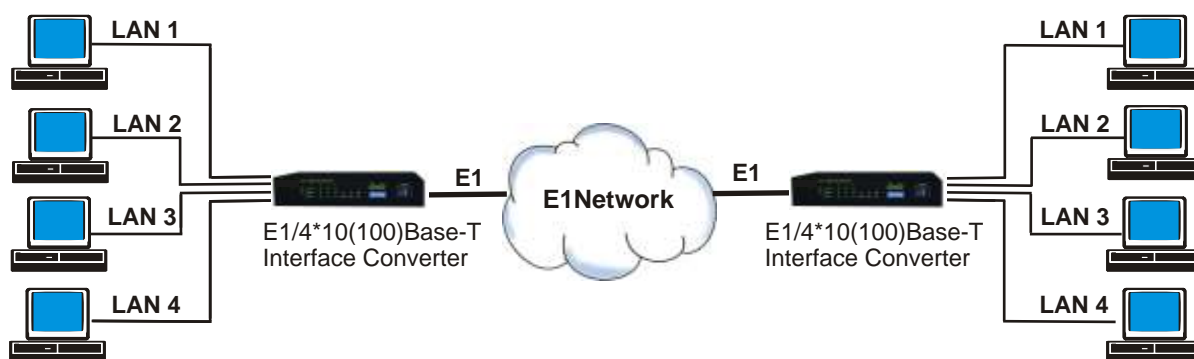

Application Diagram of VCL-4 Ethernet over 1E1 Converter in "discrete link mode"

Example: In the **discrete link mode**, the LAN 1 (Ethernet Port 1 of the equipment) only can talk to the corresponding LAN 1 (Ethernet Port 1 of the equipment) at remote side and can not talk to any other LAN, either on remote side or same side.

Note: In the **discrete link mode**, the VLAN switch must be ON (Ethernet Ports isolated) in Both the units.

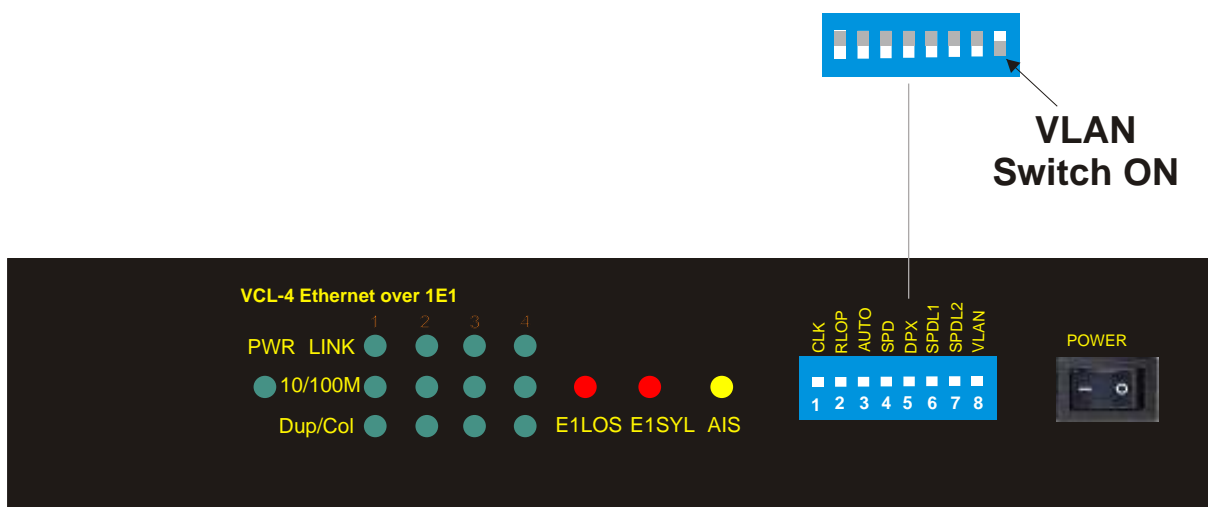

Note: Each DIP Switch is ON in downside and OFF in Upside.

Technical Features

1. The maximum transmission rate of 4 Ethernet data over E1 links is 2.048 Mbit/s
2. Supporting 1600 long frames, accordance with Interior Switching Link (ISL) Protocol
- 3 Supporting local E1 port loop-back
4. The Ethernet Port is self-adaptive to crossover or shoot-through (Straight/Parallel) cable to avoid the trouble of re-wiring
5. Supports up to four Ethernet Ports. Supports port mask
6. Ethernet negotiation function. Supports 10M/100M and working modes of both full-duplex and semi-duplex
7. Transparently transmits ultra-long frames stipulated in IEEE 802.1Q, and supports Ethernet switches with VLAN function
8. Imbedded, dynamic Ethernet MAC address list (1024 addresses), and filter function for local data frames
9. Can support multiple LANs of different network addresses
10. Optional powers 220V AC and -48V DC. May be ordered with either power option.

E1 Port specifications

Number of E1 Ports	One
Line Rate E1	(2.048 Mbps ± 50 bps)
Framing	Un-Framed
Electrical	As per ITU-T G.703
Jitter	As per ITU-T G.823
Impedance	120 Ohm (RJ-45)
Impedance	75 Ohm (BNC)

Ethernet Port specifications

Number of Ports	Four
Port Types	10/100BaseT (Auto-negotiating)
Standards Compliance	IEEE 802.3
Data Rate	10/100BaseT transmission rate limited to 2.048Mbps (maximum)
Connectors	RJ-45 (10/100 BaseT Electrical)

Installation and Commissioning

1. Qualifying the network

- The time-slots should be configured according to the planning of E1 link. If the accessed E1 link is being exclusively and only by this equipment (i.e. VCL-4 Ethernet over E1, E1/4*10(100)Base-T Interface Converter), it should be configured as transparent transmission to increase Ethernet service bandwidth

*** **Note:** Due care must be taken to ensure that the settings meet the user requirements of "shared line" or "discrete line" service

- The remote time-slots shall be configured in accordance with the local time-slots. The configuration of the equipment on both sides should be the same
- The length of the Ethernet cable shall not exceed 100m

2. Grounding

- When the equipment is used with the AC~220V power supply, the 3-core socket must be grounded for protection
- The other equipment (e.g. optical terminal) connected with this equipment must also be grounded to earth for protection

3. Installation

Step 1 Power up the Ethernet over E1 (IPoTDM) equipment.

Important: Please ensure that Ethernet over E1 (IPoTDM) equipment is powered-up prior to connecting the ethernet and the E1 links.

Step 2 Connect E1 line after ensuring that transmission device, port converter and ethernet switch have been grounded.

A Bit Error Rate (BER) test may be conducted on E1 link using a BERT tester to ensure that the E1 errors are within the permitted limits / threshold.

Step 3 Please configure the Ethernet Mode of the Ethernet over E1 (IPoTDM) equipment at both sides as well as the Ethernet Ports of the devices that are connected to the Ethernet over E1 (IPoTDM) equipment. Connect the ethernet links.

The equipment is used to bridge Multiple LANs. Please ensure that the connecting LANs on both sides of the link are operating in the same IP domain.

Step 4 Ping over the ethernet connection from one side to the other (near-end to the far-end) to verify the link.

Important Note:

Please power-up the equipment prior to connecting the ethernet and the E1 links.

Description of the Front Panel

1. Front Panel

Outline of the front panel of E1/4*10(100)Base-T Interface converter is as follows.

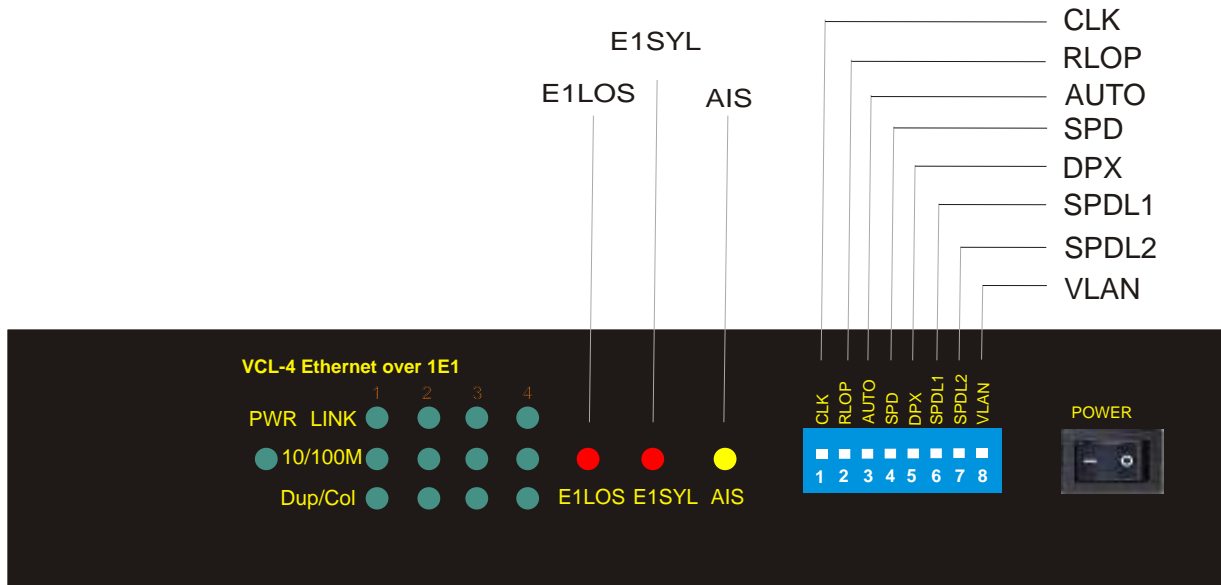

Power LED: The GREEN LED indicator lights of power supply is lit under normal working condition when the power supply is connected.

Definition of Indicators

Status of Indicator light	Ethernet Port LEDs			
	Port 1	Port 2	Port 3	Port 4
Link LED GREEN "ON" (Solid)	Input Signal Detected	Input Signal Detected	Input Signal Detected	Input Signal Detected
Link LED GREEN "ON" (Flashing)	Receiving/ Sending Data	Receiving/ Sending Data	Receiving/ Sending Data	Receiving/ Sending Data
10/100M "Green"	Port under 100M service mode	Port under 100M service mode	Port under 100M service mode	Port under 100M service mode
10/100M "OFF"	Port under 10M service mode	Port under 10M service mode	Port under 10M service mode	Port under 10M service mode
Dup/Col "ON" (Solid)	Port under full-duplex mode	Port under full-duplex mode	Port under full-duplex mode	Port under full-duplex mode
Dup/Col "OFF" (Solid)	Port under semi-duplex mode	Port under semi-duplex mode	Port under semi-duplex mode	Port under semi-duplex mode
Dup/Col "OFF" (Flashing)	Ethernet Port has detected any conflict error	Ethernet Port has detected any conflict error	Ethernet Port has detected any conflict error	Ethernet Port has detected any conflict error
Status of Indicator light	E1 Circuit LED Alarm and status			
E1 LOS RED "ON"	E1 port is unconnected or bad connected			
E1 LOS RED "OFF"	E1 port is connected properly			
AIS YELLOW "ON"	1's code alarm of E1 line			

DIP switch settings on front panel are as follows

Switch	Description			Default
1 (CLK)	ON	Internal clock: The system is running on its internal clock		ON
	OFF	Line clock: The system is drawing clock from E1 line.		
2 (RLOOP)	ON	No loop-back on E1 interface.		ON
	OFF	E1 Interface is loop-back.		
3 (AUTO)	ON	Ethernet Port is running in self-adaptive mode.		ON
	OFF	Ethernet Port rate is depend on SPD		
4 (SPD)	ON	Ethernet Port rate is 100M if "AUTO" is off		ON
	OFF	Ethernet Port rate is 10M if "AUTO" is off		
5 (DPX)	ON	Ethernet Port is running in full-duplex mode		ON
	OFF	Ethernet Port is running in semi-duplex mode		
6 and 7 (SPLD 1 and SPLD 2)	Speed Limit configuration of Ethernet Interface			ON
	SPLD 1	SPLD 2	Port Speed limit	
	ON	ON	None port is speed limit	
	ON	OFF	1 and 2 port speed, limit 512 K; 3 and 4 port, no Speed limit	
	OFF	ON	1 port speed limit, 1M; 2,3 and 4, no speed limit.	
8 (VLAN)	ON	Ethernet Port isolated (discrete link mode)		Off
	OFF	Ethernet Port is not isolated (Share link mode)		

Note: Each DIP Switch is ON in downside and OFF in Upside.

Power supply switch: To switch the power OFF/ON.

2. (A) Back Panel: AC Input

The back panel of the E1/4*10(100)Base-T 4Ethernet Over E1 (IPoTDM) equipment is as follows with AC Input

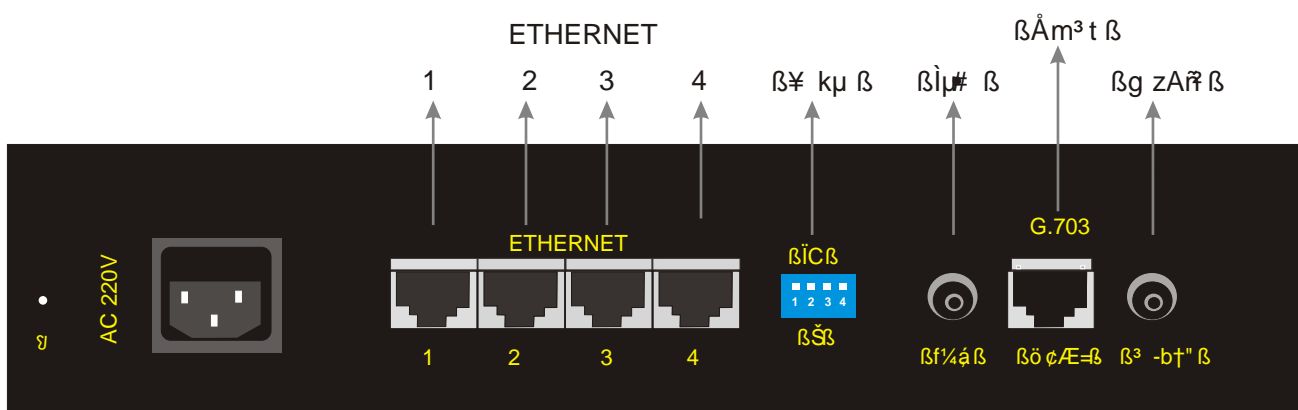

(B) Backpanel: DC Input

The back panel of the E1/4*10(100)Base-T 4Ethernet Over E1 (IPoTDM) equipment is as follows with -48V DC Input.

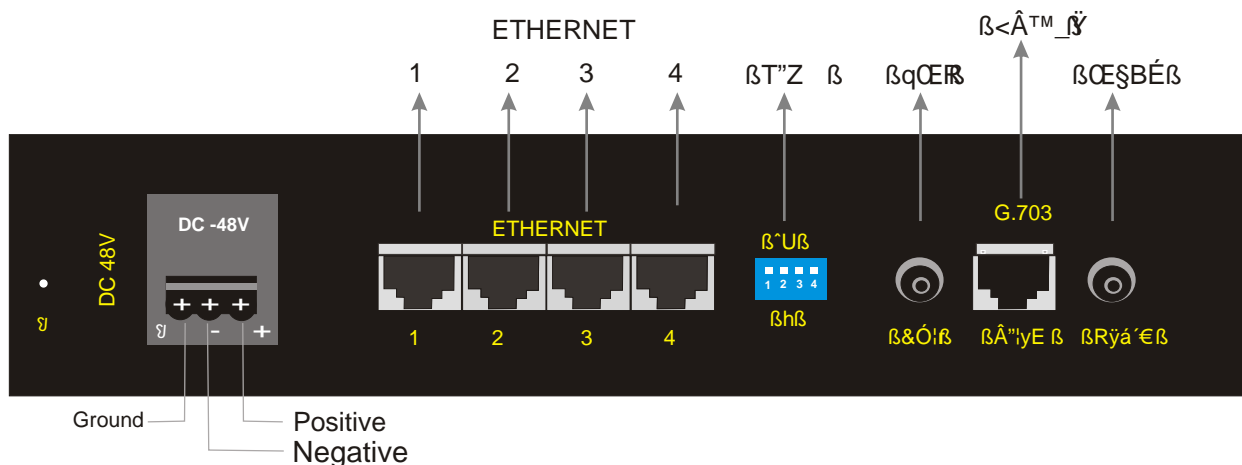

DIP switch settings on Back panel

- E1 socket for 120 W balanced: All DIP switches MUST be OFF (upside)
- E1 socket for 75 W unbalanced: All DIP switches MUST be ON (downside)

AC220V: represents the unit uses AC~220V power supply.

*Optional powers 220V AC and -48V DC. May be ordered with either power option.

E1 RJ-45 Pinouts Details

120W RJ45 pin-out		
PIN No.	Definition of function	Signal Direction
1	NC	
2	TX+ (transmitted data +)	E1 Data Output
3	TX- (transmitted data -)	E1 Data Output
4	NC	
5	NC	
6	RX+ (received data +)	E1 Data Input
7	RX- (received data -)	E1 Data Input
8	NC	

Ethernet RJ-45 Crossover Pinouts

Ethernet RJ-45 Crossover Pinouts		
PIN No.	Definition of function	Signal Direction
1	TX+ (transmitted data +)	Data Output
2	TX- (transmitted data -)	Data Output
3	RX+ (received data +)	Data Input
4	NC	
5	NC	
6	RX- (received data -)	Data Input
7	NC	
8	NC	

3. Bottom Panel:

The Bottom panel of the E1/4*10(100)Base-T 4Ethernet over E1 (IPoTDM) equipment is as follows.

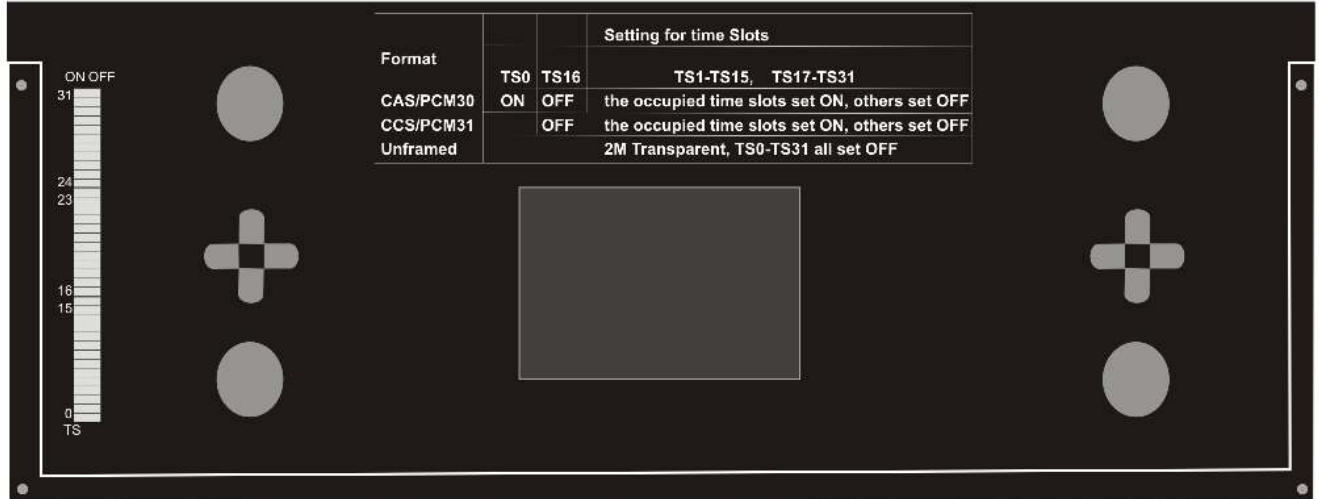

Time-slot configuration of E1 port: For E1 time-slot configuration, the DIP Switch settings on the bottom panel are as follows:

Working Mode	Switch Setting
Unframed	All switches are set to OFF
Framed (CCS/PCM-31)	S0 set to OFF, and the occupied time slots to ON
Multi-Framed (CAS/PCM-30)	All switches S0~S31 set to ON but S16 is set to OFF

The time-slot DIP switches located at the bottom of the equipment marked with TS0~TS31 bits corresponding to 0~31 time-slots of E1 channel.

Note: It is recommended to set the TS0 DIP switch OFF.

Example 1: If you wish to use only first 5 time-slots then you need to set the S0 time-slots to OFF and switch S1 to S5 to ON and time-slot S16 will be set to ON.

Example 2: If you wish to carry first 8 time-slots on 512Kbps, then you need to set the S0 time-slot OFF and switch S1 to S8 to ON (i.e. since each time-slot consumes 64Kbps, so 8 time-slots will consume 8 x 64Kbps = 512Kbps) and time-slot S16 will be set to ON.

Example 3: If you wish to carry 20 time-slots on 1.28Mbps (64Kbps x 20) then you need to set time slot S0 OFF and S1 to S21 time-slots to ON. Please remember that the time-slot S16 will be used as signaling time-slot.

Installation Instructions and Trouble-shooting

A Installation Instruction

1. Perform the following tests prior to usage:
Inspect every configuration switch on the panels to see whether they are set in normal working state, i.e. PWR and E1 LOS light ON; in the case of framed E1, E1 SYL shall be ON, other lights OFF.
2. Arrange E1 line impedance and time-slots as required, plug in E1 input/output lines and Ethernet line, then turn ON the power supply, the equipment comes into normal working conditions.
3. One equipment MUST be set to master clock and other MUST be set to line clock (loop-timed).

B Trouble-shooting

When the equipment is under normal working conditions, the three indication lights, E1LOS, E1SYL and AIS, shall be OFF.

1. Trouble: E1LOS light ON

Check point: make E1 loop-back at E1 input port and output port, if the light OFF, then highlight the check on E1 input line. Please check with the E1 Cable.

2. Trouble: E1SYL light ON

Check point: Make E1 loop-back at E1 input port and output port, if the light OFF, then highlight the check on the opposite-end interface converter to see whether set to framing service mode. If the opposite side interface converter has been set to framing service mode, check the transmission path of E1 for any disconnect. The alarm is valid if port is working on framing mode.

3. Trouble: AIS light ON

Check point: normally this fault is due to either of the following reasons:

1. The opposite-end E1 equipment cuts off receiving.
2. There are other devices working under test on E1 transmission line.
3. E1 Channel is in loop-back state.

4. Trouble: LINK light OFF

Check point: This fault is basically due to the error in making network (crossover or straight-through) cable. Please check if the equipment I require crossover cable or straight-through cable you are connecting to. VCL-4 Ethernet over E1 is self-adaptive to crossover or straight-through cable.

5. Trouble: LINK light in normal state, but data PING fails

Check point:

1. Check whether the state of the equipment Ethernet is in accordance with that of the opposite-end Ethernet; If not then, cancel the self-adaptive state of Ethernet Interface and change compulsorily to configure speed and duplex so as to be in accordance with the other end.
2. Check whether the equipment E1 port or E1 transmission channel is under loop-back or other test conditions, if any, then cancel it.
3. Check whether the time slot configuration of the local equipment is in accordance with the remote one. If not then, configure it to be in accordance.

6. Trouble: Data succeed in PING, but with frame loss

Check point: This fault may be due to the following reasons:

1. Incompatible configuration of E1 port impedance.
2. Incomplete physical connection of E1 port, e.g. only one pole connected at receiving end.
3. Wrong configuration of clock, change the clock to master clock.

7. Trouble: The communication is normal prior to configure port mask, but blocked after port mask configuration.

Check point: Ensure whether the remote equipment also configured port mask, whether the port mask configuration at two ends is in accordance; after port mask configuration, only Ethernet of same port number can perform communications. Check whether VLAN switch set to OFF (shared link mode is ON) the equipment connected to Ethernet interface, if any, Toggle the VLAN switch to ON (set the equipment for discrete link mode).

General

1. Power Supply

AC Mains Input : 220V 20% (AC Mains input model).

*Optional powers 220V AC and -48V DC. May be ordered with either power option.

Power Consumption: 10W

2. Service Conditions

Working temperature: -5°C ~ +50°C

Storage temperature: -20°C ~ +70°C

Relative humidity: 5 % ~ 95% (at 35°C)

Do not subject the equipment to corrosive solvents, gas, dust or intense magnetic-field interference.

3. **Dimensions** : 48cm x 4.3cm x 16cm

4. **Weight** : 2 Kgs.

Note: Operation and maintenance of network equipment require professional knowledge and experience. We recommend the equipment to be managed only by qualified technicians. Should you require technical assistance please consult the provider, or contact our SUPPORT DESK at support@valiantcom.com, helpdesk@valiantcom.com :

Technical specifications are subject to changes without notice.
Windows is the registered Trademark of Microsoft Corporation, USA.
Revision 07 - May 27, 2030.

AceCom Networks Pte Ltd.
200 Jalan Sultan, #02-13 Textile Centre,
Singapore 199018
Phone: +65 6295 3233, **Fax:** +65 6295 3133
E-mail: sales@acecomnet.com
Web Site: http://www.acecomnet.com